

Azimuth Over Elevation Positioners

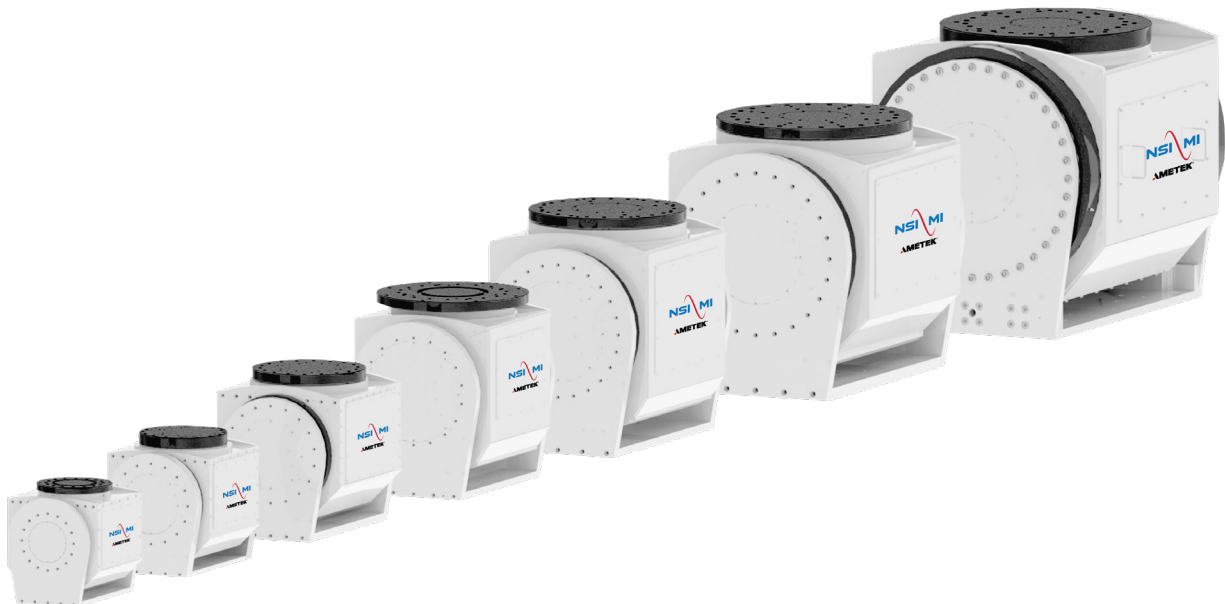

MEC-AE



FEATURES

- Bending moment up to 406,745 Nm (300,000 lb)
- Precision native accuracy & construction
- Industry leading power-density vs. size
- Payloads up to 90,718 kg (200,000 lb)
- Superior reliability & longevity
- Standardized add-on options
- Durable marine-grade finish
- All-weather design

DESCRIPTION

NSI-MI Technologies' Azimuth Over Elevation Positioners support loads up to 90,718 kg (200,000 lb) and are equipped standard with brushless servo motors, high-efficiency powertrain components, absolute encoders, and user-adjustable hardware limits. A broad selection of performance, convenience, and protection options enable you to configure your positioner for your specific application.

IDEAL FOR

- Antenna testing
- Radome measurement
- Satellite payload testing
- Radar Cross Section (RCS) measurement
- Ground communication
- General purpose positioning
- Factory automation
- Scientific and R & D

SPECIFICATIONS: LIGHT DUTY

Parameters		Units	MEC-AE-0.4	MEC-AE-1	MEC-AE-2	MEC-AE-5
Bending Moment, Static		Nm (ft-lb)	407 (300)	1,017 (750)	2,034 (1500)	5,084 (3,750)
Axial Load Capacity		kg (lb)	136 (300)	363 (800)	680 (1500)	1,361 (3,000)
Radial Load Capacity		kg (lb)	68 (150)	181 (400)	363 (800)	680 (1,500)
Delivered Torque	Azimuth	Nm (ft-lb)	244 (180)	244 (180)	678 (500)	1,085 (800)
	Elevation	Nm (ft-lb)	244 (180)	678 (500)	1,152 (850)	3,390 (2,500)
Withstand Torque	Azimuth	Nm (ft-lb)	407 (300)	407 (300)	1,017 (750)	1,627 (1,200)
	Elevation	Nm (ft-lb)	407 (300)	1,017 (750)	2,034 (1,500)	5,084 (3,750)
Maximum Speed	Azimuth	rpm	3.0	3.0	2.0	1.5
	Elevation	deg/min	1080	720	540	240
Position Readout Accuracy	Azimuth	deg	±0.05 (PF1)	±0.01 (PF4)	±0.05 (PF1) ±0.005 (PF4)	±0.05 (PF1) ±0.005 (PF4)
	Elevation	deg	±0.05 (PF1)	±0.05 (PF1) ±0.01 (PF4)	±0.05 (PF1) ±0.005 (PF4)	±0.05 (PF1) ±0.005 (PF4)
Backlash	Azimuth	deg	0.15	0.15	0.1	0.1
	Elevation	deg	0.15	0.15	0.1	0.1
Limit-to-Limit Travel	Azimuth	deg	±200 Adjustable Limit Switch (LS1) or Continuous (LS0)			
	Elevation	deg	±95			
Physical						
Thru Hole Diameter		mm (in.)	66 (2.6)	66 (2.6)	76 (3)	127 (5)
Turntable Diameter		mm (in.)	305 (12)	305 (12)	356 (14)	512 (20.5)
Height		mm (in.)	406 (16)	480 (18.9)	588 (23.1)	686 (27)
Net Weight		kg (lb)	79 (175)	113 (250)	151 (332)	333 (735)
Environmental						
Operating Conditions		N/A	Direct Outdoor Exposure			
Temperature Range	Operating	°C (°F)	-20 to 60 (-4 to 140)			
	Storage	°C (°F)	-30 to 70 (-22 to 158)			
Relative Humidity	Operating	%	100			
	Storage	%	100			
Factory Installed Options¹						
PF	Position Feedback	N/A	PF1	PF1	PF1	PF1
			N/A	PF4	PF4	PF4
RFP	RF Path Options	GHz	RJ18	RJ18	RJ18	RFP18, RJ18
			RJ26	RJ26	RJ26	RFP26, RJ26
			RJ40	RJ40	RJ40	RFP40, RJ40
			RJ50	RJ50	RJ50	RFP50, RJ50
RRU CRU	Electrical Path Options	No. of Axis	N/A	N/A	CRU1	RRU1, CRU1
RRT CRT	Electrical Path Options	No. of Conductors	CRT24	CRT24	CRT24	RRT24, CRT24
			N/A	N/A	N/A	RRT24, CRT60

¹ Refer to page 7 for factory installed options definitions.

² These options are mutually exclusive.

SPECIFICATIONS: MEDIUM DUTY

Parameters		Units	MEC-AE-12	MEC-AE-24	MEC-AE-40	MEC-AE-55
Bending Moment, Static		Nm (ft-lb)	12,202 (9,000)	24,405 (18,000)	40,675 (30,000)	54,911 (40,500)
Axial Load Capacity		kg (lb)	5,443 (12,000)	9,072 (20,000)	13,608 (30,000)	18,144 (40,000)
Radial Load Capacity		kg (lb)	2,722 (6,000)	4,536 (10,000)	6,804 (15,000)	9,072 (20,000)
Delivered Torque	Azimuth	Nm (ft-lb)	1,627 (1,200)	2,373 (1,750)	2,712 (2,000)	4,067 (3,000)
	Elevation	Nm (ft-lb)	8,135 (6,000)	16,270 (12,000)	24,405 (18,000)	36,607 (27,000)
Withstand Torque	Azimuth	Nm (ft-lb)	2,440 (1,800)	3,559 (2,625)	4,067 (3,000)	6,101 (4,500)
	Elevation	Nm (ft-lb)	12,202(9,000)	24,405 (18,000)	40,675 (30,000)	54,911 (40,500)
Maximum Speed	Azimuth	rpm	1.5	1.0	1.0	0.5
	Elevation	deg/min	90	40	30	20
Position Readout Accuracy	Azimuth	deg	±0.04 (PF1) ±0.005 (PF4)	±0.04 (PF1) ±0.005 (PF4)	±0.04 (PF1) ±0.005 (PF4)	±0.04 (PF1) ±0.005 (PF4)
	Elevation	deg	±0.05 (PF1) ±0.005 (PF4)	±0.05 (PF1) ±0.005 (PF4)	±0.05 (PF1) ±0.005 (PF4)	±0.05 (PF1) ±0.005 (PF4)
Backlash	Azimuth	deg	0.1	0.1	0.1	0.1
	Elevation	deg	0.05	0.05	0.05	0.05
Limit-to-Limit Travel	Azimuth	deg	±200 Adjustable Limit Switch (LS1) or Continuous (LS0)			
	Elevation	deg	±95			
Physical						
Thru Hole Diameter		mm (in.)	127 (5)	152 (6)	152 (6)	203 (8)
Turntable Diameter		mm (in.)	610 (24)	610 (24)	762 (30)	800 (31.5)
Height		mm (in.)	775 (30.5)	965 (38)	1,057 (41.6)	1,181 (46.5)
Net Weight		kg (lb)	748 (1,650)	1,315 (2,900)	1,814 (4,000)	2,540 (5,600)
Environmental						
Operating Conditions		N/A	Direct Outdoor Exposure			
Temperature Range	Operating	°C (°F)	-20 to 60 (-4 to 140)			
	Storage	°C (°F)	-30 to 70 (-22 to 158)			
Relative Humidity	Operating	%	100			
	Storage	%	100			
Factory Installed Options¹						
PF	Position Feedback	N/A	PF1	PF1	PF1	PF1
			PF4	PF4	PF4	PF4
RFP	RF Path Options	GHz	RFP18, RJ18	RFP18, RJ18	RFP18, RJ18	RFP18, RJ18
			RFP26, RJ26	RFP26, RJ26	RFP26, RJ26	RFP26, RJ26
			RFP40, RJ40	RFP40, RJ40	RFP40, RJ40	RFP40, RJ40
			RFP50, RJ50	RFP50, RJ50	RFP50, RJ50	RFP50, RJ50
RRU CRU	Electrical Path Options ²	No. of Axis	RRU1, CRU1	RRU1, CRU1	RRU1, CRU1	RRU1, CRU1
			RRU2, CRU2	RRU2, CRU2	RRU2, CRU2	RRU2, CRU2
RRT CRT	Electrical Path Options ²	No. of Conductors	RRT24, CRT24	RRT24, CRT24	RRT24, CRT24	RRT24, CRT24
			RRT60, CRT60	RRT60, CRT60	RRT60, CRT60	RRT60, CRT60

¹ Refer to page 7 for factory installed options definitions.

² These options are mutually exclusive.

SPECIFICATIONS: HEAVY DUTY

Parameters		Units	MEC-AE-120	MEC-AE-180	MEC-AE-300	MEC-AE-400
Bending Moment, Static		Nm (ft-lb)	122,024 (90,000)	183,035 (135,000)	305,059 (225,000)	406,745 (300,000)
Axial Load Capacity		kg (lb)	34,019 (75,000)	40,823 (90,000)	68,039 (150,000)	45,359 (100,000)
Radial Load Capacity		kg (lb)	18,144 (40,000)	20,412 (45,000)	45,359 (100,000)	22,680 (50,000)
Delivered Torque	Azimuth	Nm (ft-lb)	13,558 (10,000)	17,626 (13,000)	40,675 (30,000)	54,233 (40,000)
	Elevation	Nm (ft-lb)	81,349 (60,000)	122,024 (90,000)	183,035 (135,000)	203,373 (150,000)
Withstand Torque	Azimuth	Nm (ft-lb)	20,337 (15,000)	26,438 (19,500)	61,012 (45,000)	74,570 (55,000)
	Elevation	Nm (ft-lb)	122,024 (90,000)	183,035 (135,000)	305,059 (225,000)	406,745 (300,000)
Maximum Speed	Azimuth	rpm	0.5	0.5	0.2	0.2
	Elevation	deg/min	30	20	12	10
Position Readout Accuracy	Azimuth	deg	±0.03 (PF1) ±0.005 (PF4)	±0.02 (PF1) ±0.005 (PF4)	±0.02 (PF1) ±0.005 (PF4)	±0.02 (PF1) ±0.005 (PF4)
	Elevation	deg	±0.04 (PF1) ±0.005 (PF4)	±0.05 (PF1) ±0.005 (PF4)	±0.04 (PF1) ±0.005 (PF4)	±0.03 (PF1) ±0.005 (PF4)
Backlash	Azimuth	deg	0.03	0.05	0.03	0.02
	Elevation	deg	0.03	0.03	0.03	0.02
Limit-to-Limit Travel	Azimuth	deg	±200 Adjustable Limit Switch (LS1) or Continuous (LS0)			
	Elevation	deg	±95	+92/-45	±95	+92 / -20
Physical						
Thru Hole Diameter		mm (in.)	254 (10)	152 (6)	203 (8)	203 (8)
Turntable Diameter		mm (in.)	965 (38)	1,201 (47.3)	1,194 (47)	2,223 (87.5)
Height		mm (in.)	1,537 (60.5)	1,643 (64.7)	1,862 (73.3)	3,023 (119)
Net Weight		kg (lb)	5,080 (11,200)	3,538 (7,800)	9,072 (20,000)	15,876 (35,000)
Environmental						
Operating Conditions		N/A	Direct Outdoor Exposure			
Temperature Range	Operating	°C (°F)	-20 to 60 (-4 to 140)			
	Storage	°C (°F)	-30 to 70 (-22 to 158)			
Relative Humidity	Operating	%	100			
	Storage	%	100			
Factory Installed Options¹						
PF	Position Feedback	N/A	PF1	PF1	PF1	PF1
			PF4	PF4	PF4	PF4
RFP	RF Path Options	GHz	RFP18, RJ18	RFP18, RJ18	RFP18, RJ18	RFP18, RJ18
			RFP26, RJ26	RFP26, RJ26	RFP26, RJ26	RFP26, RJ26
			RFP40, RJ40	RFP40, RJ40	RFP40, RJ40	RFP40, RJ40
			RFP50, RJ50	RFP50, RJ50	RFP50, RJ50	RFP50, RJ50
RRU CRU	Electrical Path Options	No. of Axis	RRU1, CRU1	RRU1, CRU1	RRU1, CRU1	RRU1, CRU1
			RRU2, CRU2	RRU2, CRU2	RRU2, CRU2	RRU2, CRU2
RRT CRT	Electrical Path Options	No. of Conductors	RRT24, CRT24	RRT24, CRT24	RRT24, CRT24	RRT24, CRT24
			RRT60, CRT60	RRT60, CRT60	RRT60, CRT60	RRT60, CRT60

¹ Refer to page 7 for factory installed options definitions.

² These options are mutually exclusive.

MEC-AE POSITIONER DIMENSIONAL CONFIGURATIONS

MEC-AE-0.4	MEC-AE-1	MEC-AE-2	MEC-AE-5
------------	----------	----------	----------

Top View

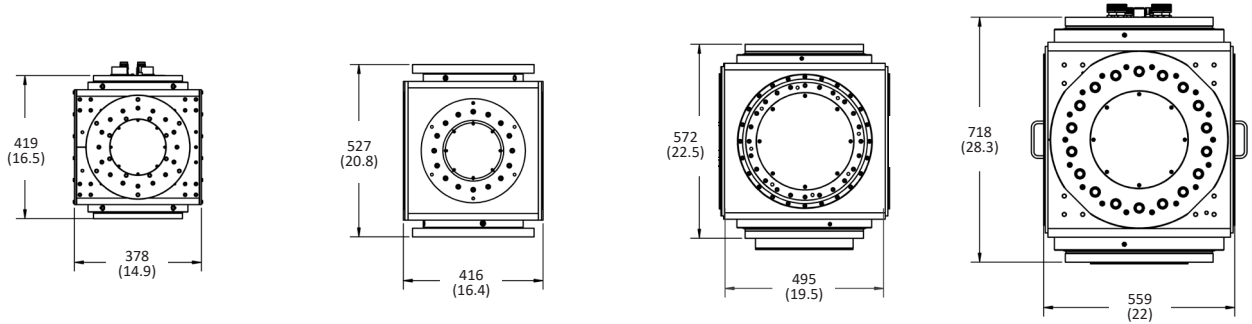

Front View

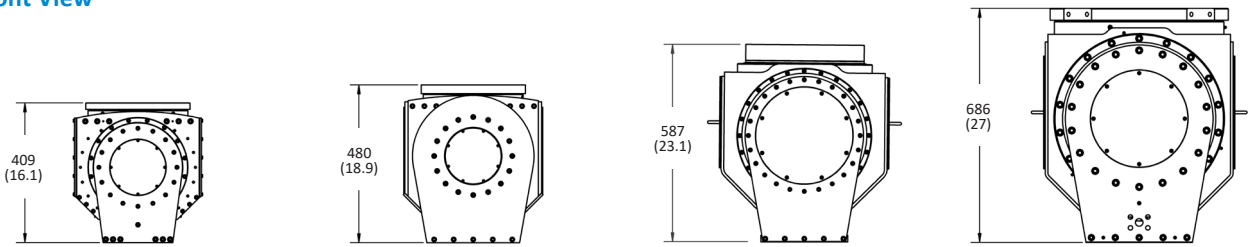

MEC-AE-12	MEC-AE-24	MEC-AE-40	MEC-AE-55
-----------	-----------	-----------	-----------

Top View

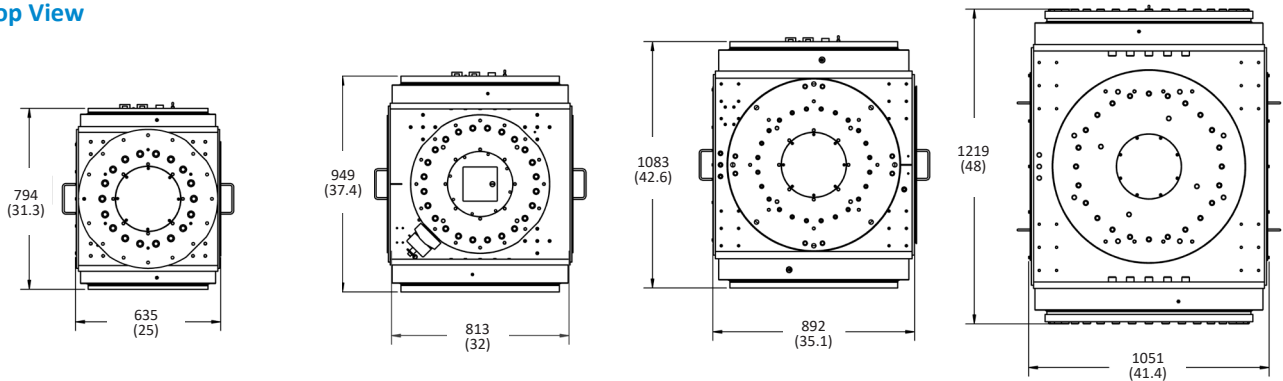

Front View

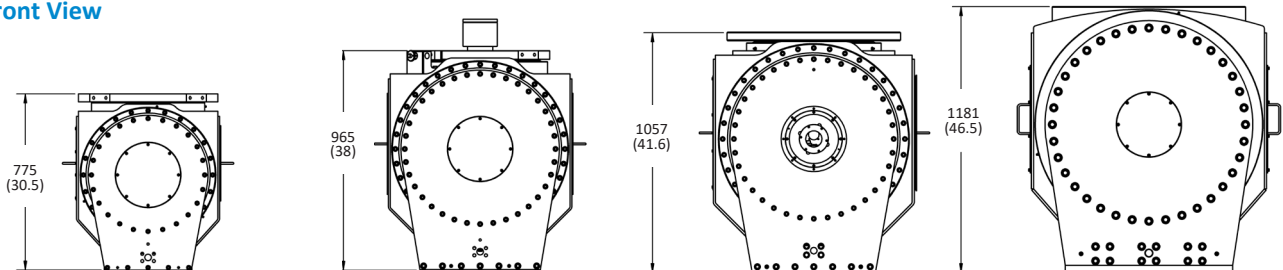

All dimensions are in mm (in.)

MEC-AE POSITIONER DIMENSIONAL CONFIGURATIONS

MEC-AE-120	MEC-AE-180	MEC-AE-300	MEC-AE-400
------------	------------	------------	------------

Top View

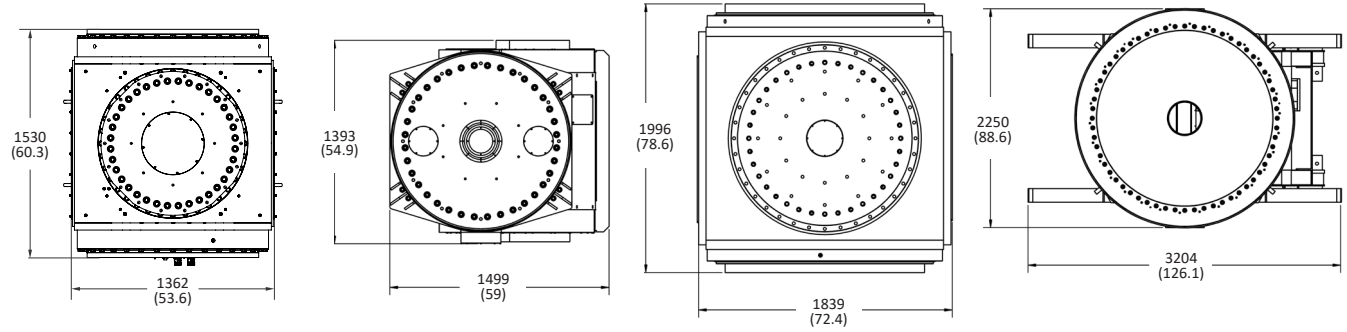

Front View

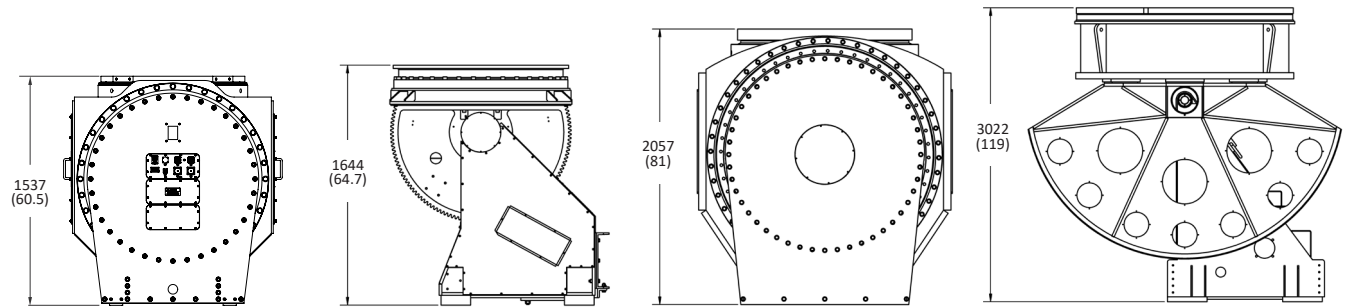

All dimensions are in mm (in.)

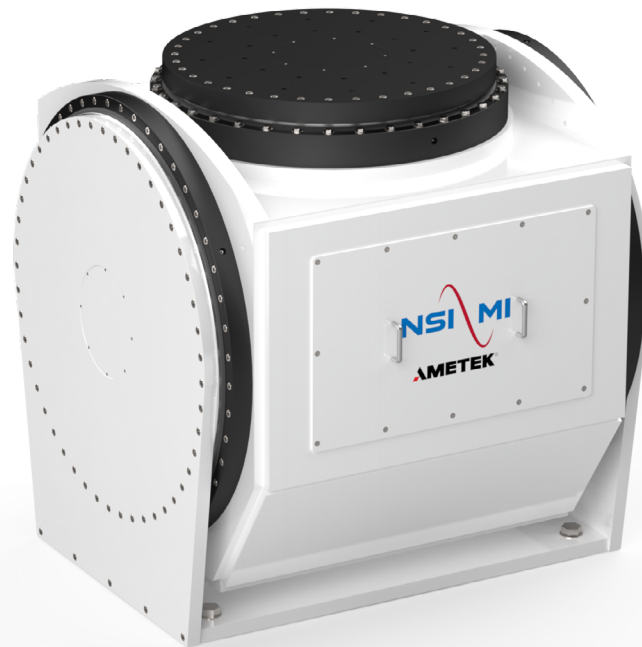

FACTORY INSTALLED OPTIONS

POSITION FEEDBACK OPTIONS



PF1: Off-Axis Absolute Encoder
Standard absolute feedback with Encoder



PF4: High Accuracy, ± 0.005 degrees native read-out accuracy for most positioners
Replaces standard absolute feedback with center-drive high accuracy absolute encoder

Notes: Options are available to further enhance the native accuracy using error correction techniques. See Enhanced Accuracy Options brochure for additional information.

LIMIT SWITCH OPTIONS

LS0: No Limits, Continuous Rotation

LS1: Restricted Rotation up to ± 200 degrees (adjustable)

RF PATH OPTIONS



RJ Rotary Joint (Continuous Rotation)

Adds a single channel RF path inside the positioner supporting continuous, unrestricted rotation of the axis. The factory installed kit contains RF rotary joint and internal RF cabling.

RJ18: DC-18 GHz, SMA

RJ26: DC-26.5 GHz, 3.5 mm

RJ40: DC-40 GHz, K

RJ50: DC-50 GHz, 2.4 mm



RF Path (Restricted Rotation)

Adds a single channel RF path inside the positioner with restricted travel of the positioner up to a ± 200 degree travel range. The factory installed kit contains internal RF cabling.

RFP18: DC-18 GHz, SMA

RFP26: DC-26.5 GHz, 3.5 mm

RFP40: DC-40 GHz, K

RFP50: DC-50 GHz, 2.4 mm

ELECTRICAL PATH OPTIONS

CRU (Continuous Rotation for Upper-Axes)

Adds an electrical path inside the positioner supporting continuous unrestricted rotation of the upper motorized axis. The factory installed kit includes an internal electrical slip-ring assembly and internal wiring.

CRU1: Wiring Support for One (1) Axis

CRU2: Wiring Support for Two (2) Axes

CRU3: Wiring Support for Three (3) Axes

RRU (Restricted Rotation for Upper-Axes)

Adds an electrical path for upper motorized axes inside the positioner supporting restricted rotation up to ± 200 degrees. The factory installed kit includes internal wiring.

RRU1: Wiring Support for One (1) Axis

RRU2: Wiring Support for Two (2) Axes

RRU3: Wiring Support for Three (3) Axes

CRT (Continuous Rotation for Thru-Contacts)

Adds an electrical path inside the positioner supporting continuous unrestricted rotation for dedicated thru-contacts. The factory installed kit contains an internal electrical slip-ring assembly and internal wiring.

Applications: RF switch control, amplifier DC power, attenuation control.

CRT24: Thru-Contacts, 24 Contacts

CRT60: Thru-Contacts, 60 Contacts

RRT (Restricted Rotation for Thru-Contacts)

Adds an electrical path inside the positioner supporting restricted rotation up to ± 200 degrees for dedicated thru-contacts. The factory installed kit contains an internal wiring harness, cap and chain protectors.

Applications: RF switch control, amplifier DC power, attenuation control.

RRT24: Thru-Contacts, 24 Contacts

RRT60: Thru-Contacts, 60 Contacts

CONVENIENCE & PROTECTION OPTIONS



Stow-Pin:

Adds manual stow-pin and mating receptacle to protect the positioner's drive-train in susceptible environments such as high wind-gust exposure in outdoor environments and high-load pick-up mode applications. Includes electrical interlock circuit for disabling the servo system when stow-pin is inserted. Default position is zero (0) degrees. Alternate stow-pin angle locations are available upon request.

SP1 – Stow-Pin, Azimuth / Polarization

SP2 – Stow-Pin, Elevation

Riser:

Adds a structural riser below the positioner for applications requiring accurate centering from a platform, outdoor silo applications, and various customer requested heights. Risers are designed to withstand the full capacity of the mated positioner and are tailored to your required height. Available features include access hatches, custom color, internal shelving, and external and internal ladders.

RS1 – Riser



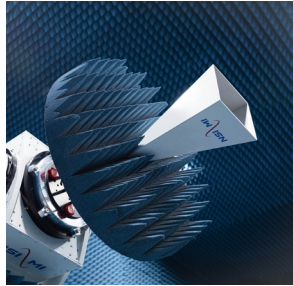
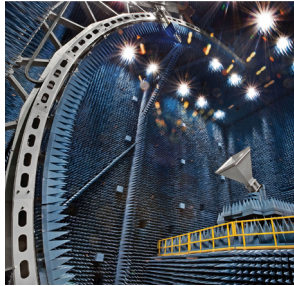
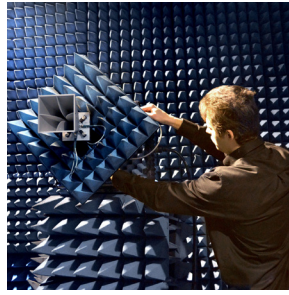
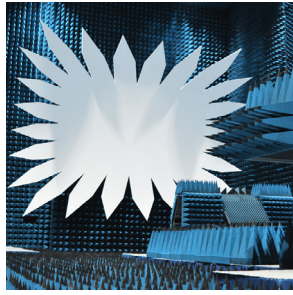
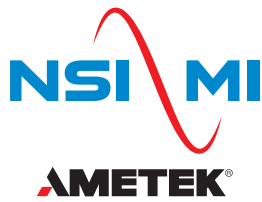

LOCATIONS

1125 Satellite Blvd., Suite 100
Atlanta, Georgia 30024-4629
USA

+1 678 475 8300

19730 Magellan Drive
Torrance, CA 90502-1104
USA

+1 310 525 7000

Stubley Lane,
Dronfield, S18 1DJ
UK

+44 1246 581500

NSI-MI Technologies introduced the world to microwave antenna measurement systems and is the preferred global supplier of antenna, radar cross section, and radome measurement solutions. Today, our innovative products, systems, and services lead the industry in setting new standards for tomorrow's performance. From world-class in-house testing facilities to delivering industry-leading turnkey systems, we provide the highest quality measurement products on the market.

Our full range of standard products and custom-designed systems are backed by our longstanding commitment to precision-engineered accuracy, reliability, and lasting performance. We provide the right solution for every RF measurement need and our worldwide network of service professionals are always available to offer support.

For more information on ordering NSI-MI Technologies' products, applications or services please contact your nearest NSI-MI office. Our complete sales team information is available at: www.nsi-mi.com/contact-us

ISO 9001:2015 COMPLIANT

